

SCHMEISER® FOLDING TILL AN' BEDDER

ASSEMBLY & PARTS MANUAL

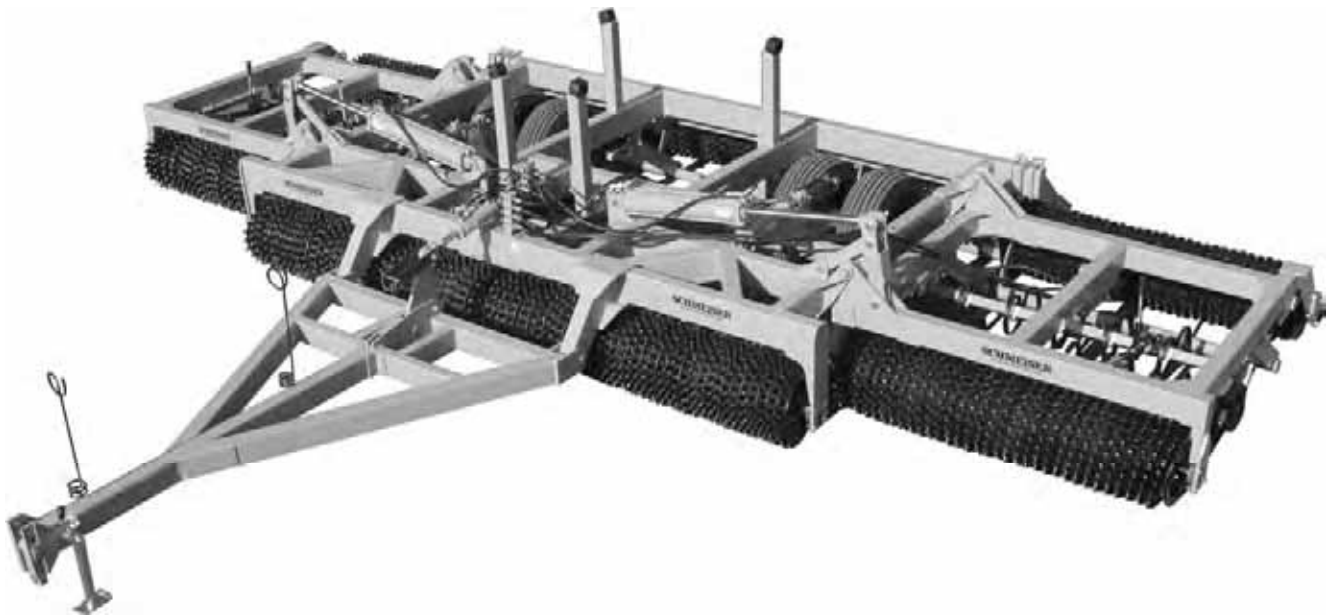

T.G. SCHMEISER CO., INC.
P.O. BOX 1047 FRESNO, CA. 93714
(559) 268-8128 FAX (559) 268-3279
www.tgschmeiser.com

VERSION 1.0
3-2007

INTRODUCTION

Your Schmeiser Till An' Bedder is designed to give you many years of dependable service. This manual has been prepared to instruct you in the safe and efficient operation of this machine. Read and study it thoroughly. Follow all instructions carefully.

Should your Till An' Bedder require replacement parts, go to your Schmeiser dealer. Always order genuine Schmeiser replacement parts.

It is important that you complete and send in your Warranty Card because it is not valid unless it is on file at Schmeiser. If you need information not contained in this manual, contact your Schmeiser dealer.

Space has been provided below for you to record the model number and serial number of your Till An' Bedder. Be sure to bring this information with you to your dealer when ordering parts or attachments for your Till An' Bedder.

Thank you for buying a Schmeiser Till An' Bedder.

SERIAL NUMBER _____

MODEL NUMBER _____

DATE PURCHASED _____

DEALER NAME _____

TABLE OF CONTENTS

Introduction	2
Table of Contents.....	3
Safety Sheet.....	4
Folding Till An' Bedder Set Up Instructions.....	5
Folding Till An' Bedder Assembly	6
Folding Till An' Bedder Pull Frame Assembly 24' and 28' Units.....	8
Folding Till An' Bedder Pull Frame Assembly 30' Units.....	9
Folding Till An' Bedder Hitch Assembly	10
Folding Till An' Bedder Hinge Linkage Assembly.....	11
S-Tine Assembly	12
S-Tine Tie Clamp Assembly.....	13
Wheel Axle Bearing Assembly.....	14
Folding Till An' Bedder Wheel Axle Assembly.....	15
Rock Shaft to Leveling Pipe Frame Assembly.....	16
Rock Shaft to Main Frame (Wing Frame) Assembly.....	17
FTB Rear Roller Assembly.....	18
Folding Till An' Bedder Hydraulic Instructions.....	19
Hydraulic Diagram for FTB Wheel Axle & Pull Frame 24' and 28' Units.....	20
Hydraulic Diagram for FTB Wheel Axle & Pull Frame 30' Units.....	21
Hydraulic Diagram for Folding Till An' Bedder Wings.....	22
Hydraulic Diagram for Folding Till An' Bedder Rock Shaft.....	23
Limited Warranty.....	24

SAFETY

The safe operation of any machinery is an important concern to farmers and manufactures. There are obvious and hidden potential hazards involved in the operation of this implement. Carefully read and follow all safety precautions before operation. Serious injury or death may occur unless care is taken to insure the safety of both the operator and any other persons in the area.

1. Never permit anyone to ride on or walk beside the implement when moving.
2. Never permit anyone to ride on tractor when implement is being moved.
3. When performing operating functions, never allow anyone to be near the implement or the tractor.
4. Do not enter tractor when tractor is moving. Avoid serious injury or death from contact with rotating tires. Enter and exit the tractor only when it is completely stopped.
5. Be sure of water, gas, sewer, or electric line locations before operating implement.
6. When in transport, use accessory lights and devices for adequate warning to operators of other vehicles. Comply with all Federal, State and local laws when traveling on public roads.
7. Use "Slow Moving Vehicle" emblem for warning vehicles approaching from the rear.
8. When transporting, remember that the implement may be wider than your tractor and extreme care must be taken to allow for safe clearance.
9. Never allow inexperienced or untrained personnel to operate the implement or tractor without supervision.
10. When using compressed air to clean implement, wear safety glasses.
11. Check all fasteners for tightness or damage before and after operation. Repair immediately if required.
12. Store implement in a stable position. Insure that safety stands are extended and locked in place before detaching from tractor.

FOLDING TILL AN' BEDDER SET UP INSTRUCTIONS

THE FOLLOWING TOOLS ARE NEEDED:

1. Overhead hoist or forklift.
2. Impact gun or socket wrench with 3/4", 1-1/8", 1-5/16" and 1-1/2" sockets.
3. 3/16" allen wrench.
4. Pry bar
5. 14" tapered drift punch.

PROCEDURE:

1. Select a smooth, level piece of ground of approximately 50' x 50' to assemble the SCHMEISER Folding Till An' Bedder. Place the main body of the machine in the center of the ground facing in the direction in which it is to be pulled. Leave Wings in folded position. Do not install Pull Frame yet as this will obstruct access to main body of machine.
2. Lift rear of machine approximately 3'. Rotate Wheel Axle to fully extend the (2) 4 x 12 Hydraulic Cylinders. Swing (2) Cylinder Lockout Bars into lock position. Secure lockouts with safety clevis pins provided. Lower rear of unit with Wheel Axle now in locked position.
3. Mount both left and right Rear Roller Arms to rear cross bar of Main Frame as shown on page 17. Insure that the Rear Roller Arm top plates are just to the inside of the 1/2" square stops on the rear cross bar. Also insure that the bearing mounting plates face out. Install 7/8" Square U-bolts and 3/4" x 10" with lock washers and hex nuts, hand tighten only.
4. Mount all (12) 1-15/16" flange bearings onto all Ring Roller bearing shafts using a 3/16" allen wrench.
5. Mount one of the Main Frame Ring Rollers to the front of the machine using 1/2" x 2-1/4" hex bolts with flat washers, lock washers, and hex nuts. Tighten all bolts. For packing, front teeth of rings should aim down. For tilling, front teeth should aim up.
6. Mount the remaining Main Frame Ring Roller to the Rear Roller Arms using 1/2" x 2-1/4" hex bolts with flat washers, lock washers, and hex nuts. Tighten all 1/2" hex bolts. Once the rear roller is mounted, tighten Rear Roller Arm bolts.
7. Lift rear of unit to take the weight off of the Wheel Axle Cylinder Lockout Bars. Swing lockouts up and lower unit to the ground.
8. With Wings still in folded position, mount all Wing Rollers to the Wing Frames, using 1/2" x 2-1/4" hex bolts with flat washers, lock washers, and hex nuts. Tighten all bolts. NOTE: When mounting rollers this way, insure that the ring teeth are aiming in the opposite direction of the Main Frame Ring Rollers. Once the wings are unfolded, all the teeth will be aiming in the same direction.
9. Mount Pull Frame to Main Frame pull arms using 1" x 7" hex bolts with nylon lock nuts. Install 3-1/2 x 8 Hydraulic Cylinder (two cylinders for 30' units) to Main Frame and Pull Frame Pivot Link and Lockout Bar as shown on page 10, using 1" x 3" hex bolts with nylon lock nuts. Install Hose Holders and connect Lead Hoses to Hydraulic Manifold and Tractor.
10. **BEFORE ENGAGING ANY HYDRAULIC CYLINDERS, INSURE THAT NO ONE IS ANYWHERE NEAR THE IMPLEMENT OR TRACTOR.** Insure that there are no overhead and/or other obstructions. All hydraulic lines must be free of debris and air and completely full of hydraulic fluid prior to field operation. While still in folded position, extend and retract rear leveling pipe cylinders until smooth operation is achieved. Keeping wings folded, lift and lower entire unit completely several times until all cylinders work as intended. Always raise unit fully off the ground prior to folding or unfolding wings. Take special care when unfolding wings as they go over center. Fold and unfold wings until unit works smoothly.



<u>Ref No.</u>	<u>Part No.</u>	<u>Description</u>	<u>Qty.</u>
	GWD-150SC1	Ua * ^ Sa Hitch	1
2.	GJK-5KTW10	Jack Stand	1
3.	FTB-00A000	FTB Pull Frame Weldment (specify unit size)	1
4.	TBU-00D000	Front Linkage Pivot Plate	varies
5.	FTB-00F000	FTB Main Frame Weldment (specify unit size)	1
6.	FTB-00K000	FTB Wing Weldment - Pair (specify unit size)	1
7.	-----	Main Frame Ring Roller(specify unit size)	2
8.	-----	Wing Ring Roller (specify unit size)	4
9.	FTB-00J000L(R)	FTB Rear Roller Arm Weldment LH and RH	2
10.	FTB-00M000	FTB Wheel Axle Weldment (specify unit size)	1
11.	GWD-412LB1	Wheel Axle Lockout Bar Weldment	2



T. G. SCHMEISER CO., INC.

FOLDING TILL AN' BEDDER ASSEMBLY

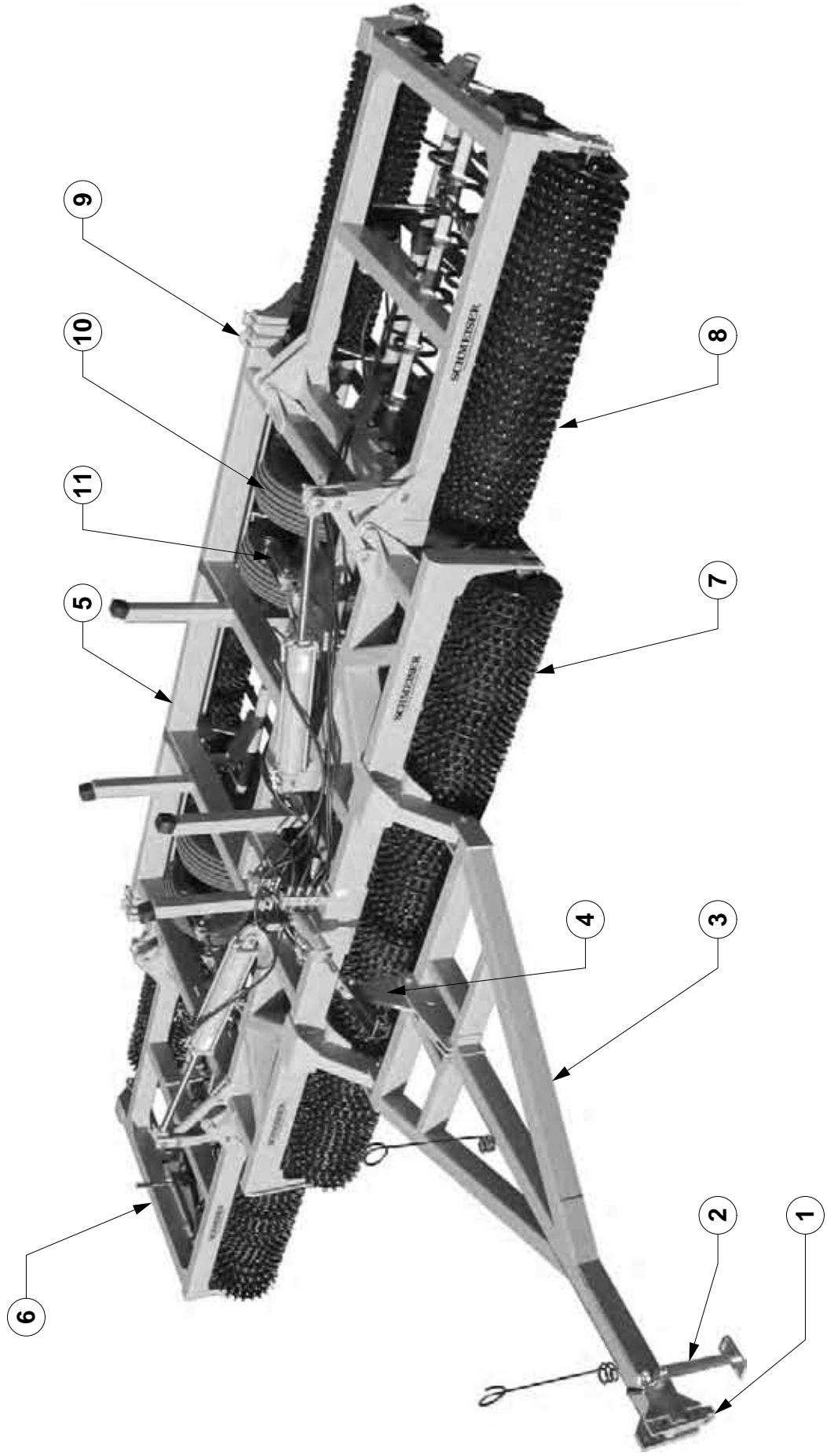

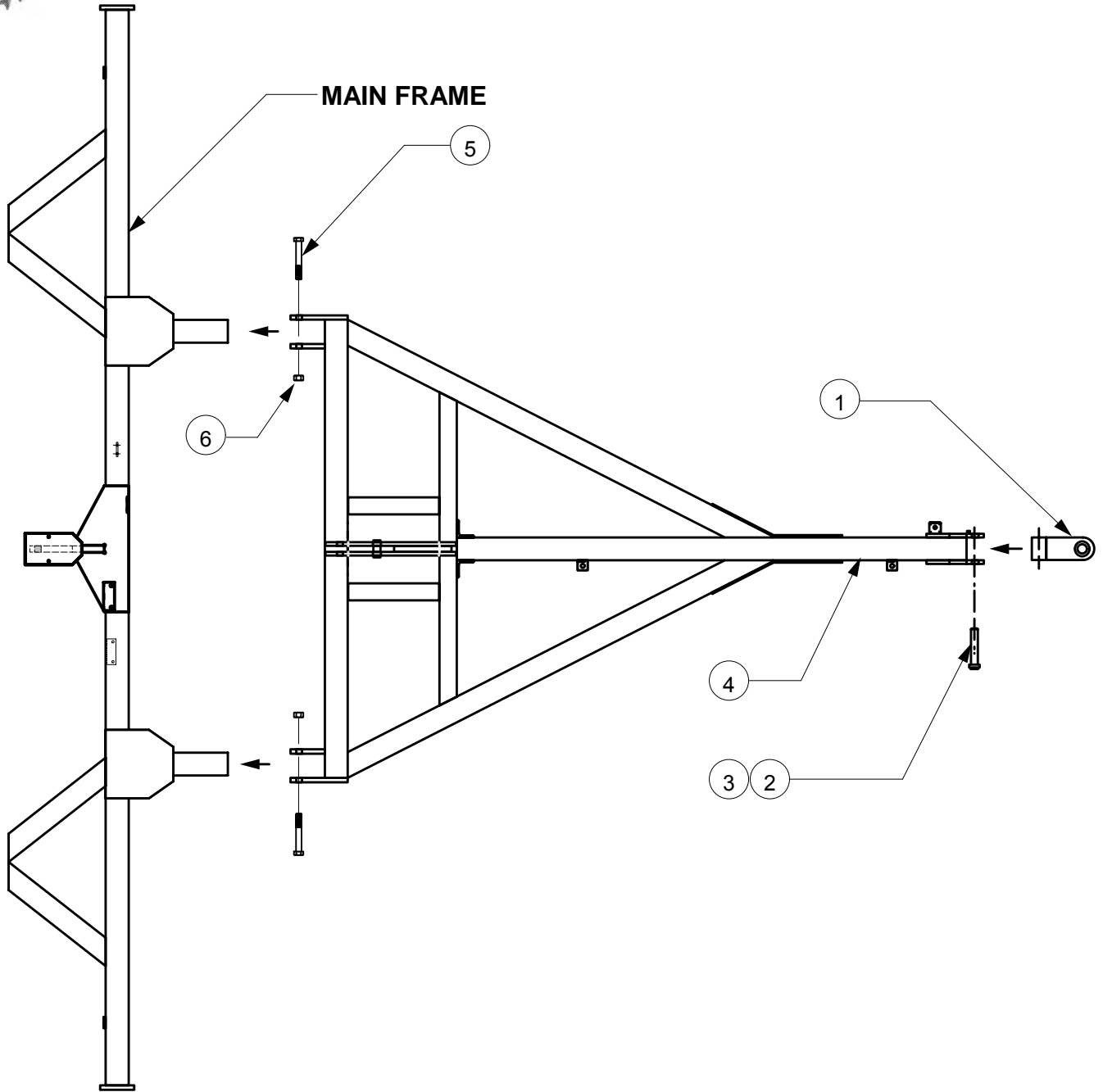

<u>Ref No.</u>	<u>Part No.</u>	<u>Description</u>	<u>Qty.</u>
1.	GWD-150SC1	Single Lip Hitch	1
2.	GPN-18A200	1-1/8" X 6-1/2" Clevis Hitch Pull Pin	1
3.	GPN-040LYN	1/4" X 3" Lynch Pin	1
4.	FTB-00A100	Pull Frame for 24' and 28' Units	1
5.	CSNC516112	1" X 7" NC Cap Screw	2
6.	NYNUT-16NC	1" Nylon NC Hex Nut	2

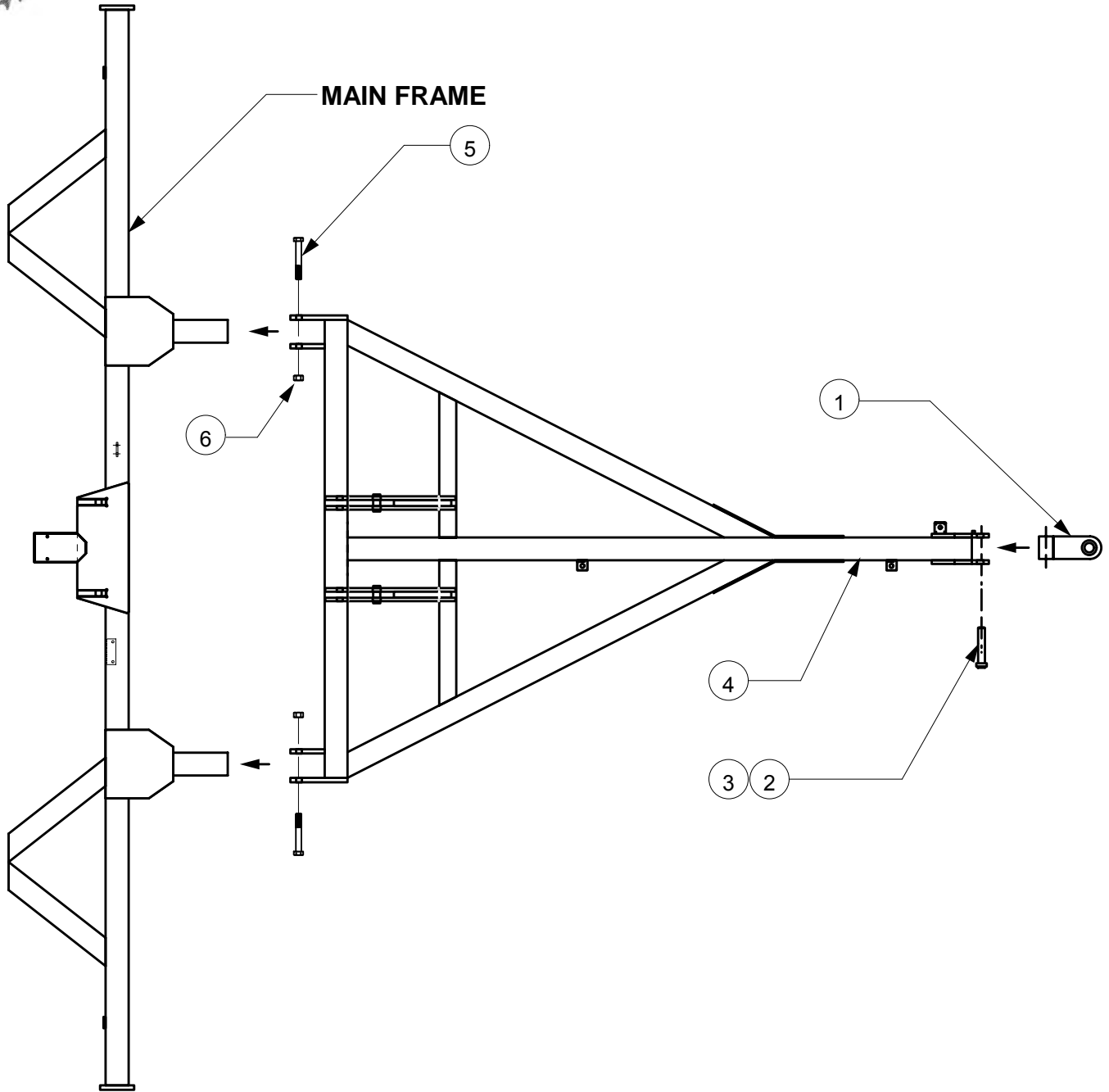

<u>Ref No.</u>	<u>Part No.</u>	<u>Description</u>	<u>Qty.</u>
1.	GWD-150SC1	Single Lip Hitch	1
2.	GPN-18A200	1-1/8" X 6-1/2" Clevis Hitch Pull Pin	1
3.	GPN-040LYN	1/4" X 3" Lynch Pin	1
4.	FTB-00A200	Pull Frame for 30' Units	1
5.	CSNC516112	1" X 7" NC Cap Screw	2
6.	NYNUT-16NC	1" Nylon NC Hex Nut	2

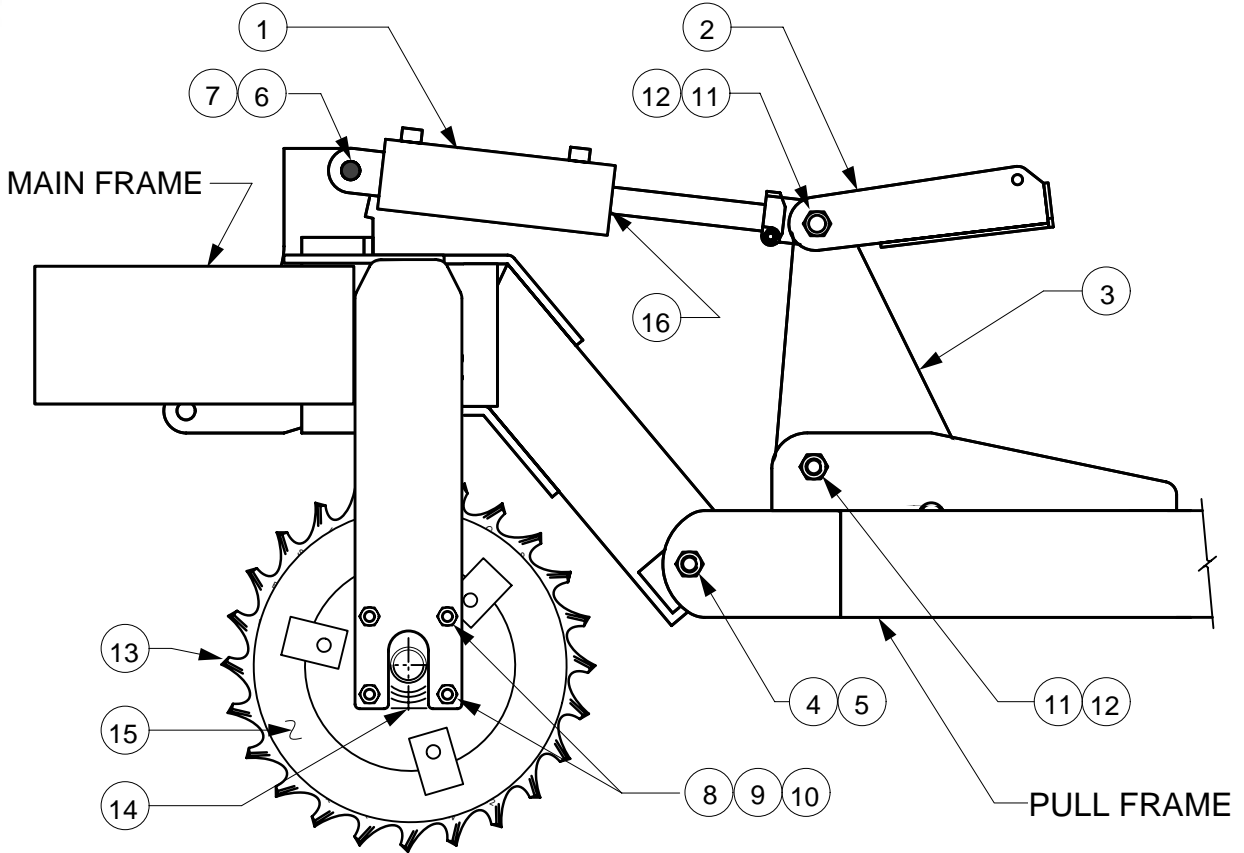

Tube Size	Ring Size (ID / OD)	Ring Part #	Retainer Size (ID - OD)	Retainer Part #
10"	12 / 17	TPP3357	10 - 14	TPP3206
10"	13 / 17	TPP3352	10 - 16	TPP3207
12"	14 / 20	TPP3353	12 - 18	TPP3210

Ref No.	New Part No.	Old Part No.	Description	24'-28' Units	30' Units
1.	GHC-35080W	SLL 1300	3.5" X 8" Welded Hydraulic Cyl.	1	2
2.	GWD-358LB1		Lockout Bar For 3.5" X 8" Hydraulic Cyl.	1	2
3.	TBU-00D000	TB4-D	Till An' Bedder Pivot Plate	1	2
4.	CSNC516112		1" X 7" NC Cap Screw Gr. 5	2	2
5.	NYNUT-16NC		1" NC Nylon Hex Nut	2	2
6.	GPN-16X040		1" X 2-1/2" Clevis Pin	1	2
7.	GPN-04X28C		1/4" X 1-3/4" Cotter Pin	1	2
8.	CSNC508036		1/2" X 2-1/4" NC Cap Screw Gr. 5	48	48
9.	LWASHER-08		1/2" Lock Washer	48	48
10.	HXNUT-08NC		1/2" NC Hex Nut	48	48
11.	CSNC516048		1" X 3" NC Cap Screw Gr. 5	2	4
12.	NYNUT-16NC		1" NC Nylon Hex Nut	2	4
13.	-----		Specify Ring Size (see table for all sizes)	10 /ft	10 /ft
14.	TPP 3152	TPP 3152	1-11/16" Flange Bearings	12	12
15.	-----		Roller Retainer (see table for all sizes)	12	12
16.	PMCK-43500		Seal Kit for 3-1/2" x 8" Welded Cylinder	1	2

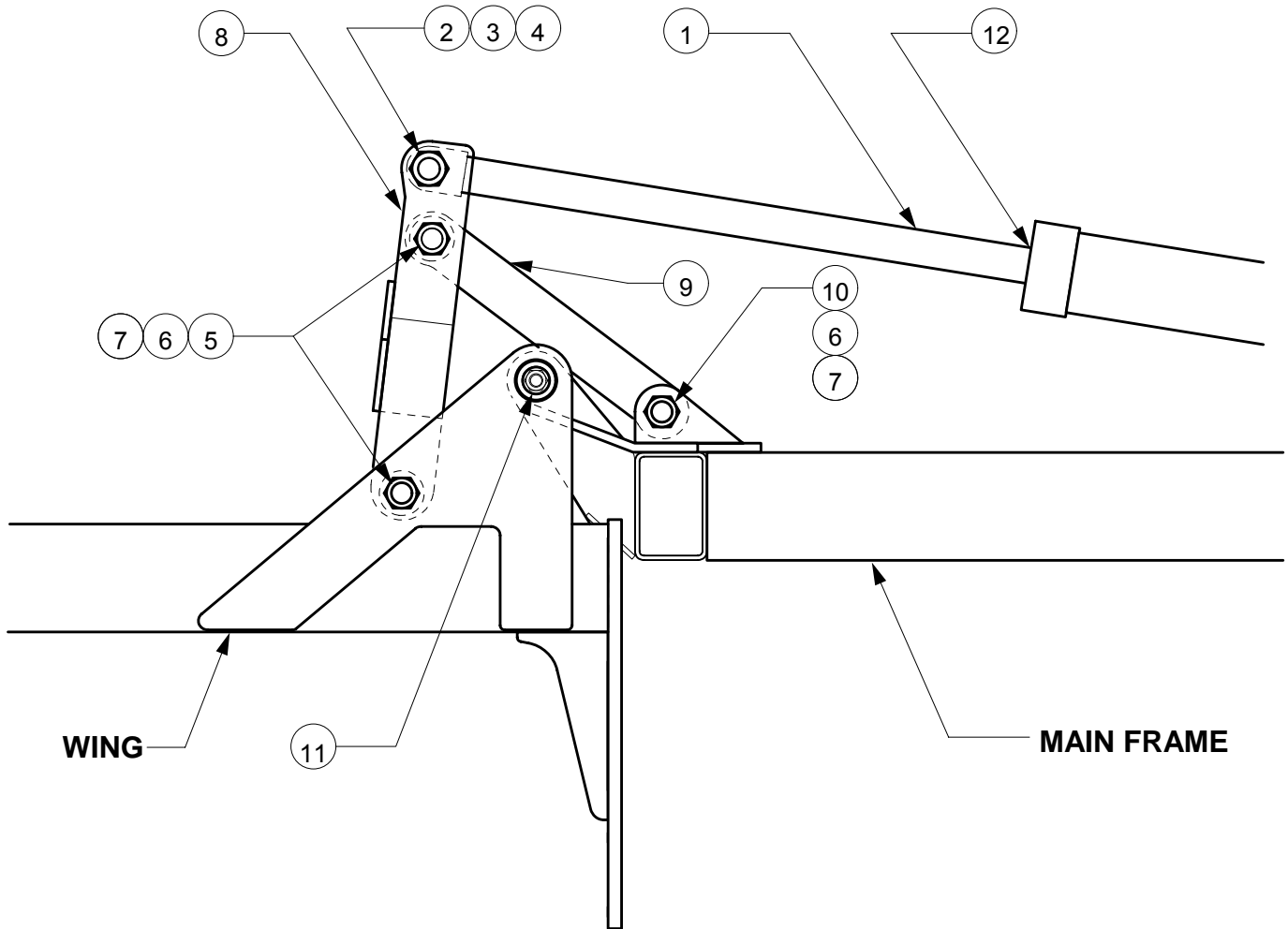

<u>Ref No.</u>	<u>New Part No.</u>	<u>Description</u>	<u>Qty.</u>
1.	GHC-50300T	5" x 30" Hydraulic Cylinder	2
2.	CSNC820112	1-1/4" x 7" NC Gr.8 Cap Screw	2
3.	HXNUT-20NC	1-1/4" NC Hex Nut	2
4.	LWASHER-20	1-1/4" Lock Washer	2
5.	CSNC818112	1-1/8" x 7" NC Gr.8 Cap Screw	4
6.	HXNUT-18NC	1-1/8" NC Hex Nut	4
7.	LWASHER-18	1-1/8" Lock Washer	4
8.	GWD-WHLINK	Hinge Link Weldment	2
9.	GPR-L10003	Loose Link	2
10.	CSNC818080	1-1/8" x 5" NC Gr.8 Cap Screw	2
11.	GPN-HING01	1-1/2" x 9-1/2" Hinge Pin	4
12.	PMCK-3500	Seal Kit for 5" x 30" Hydraulic Cylinder	1

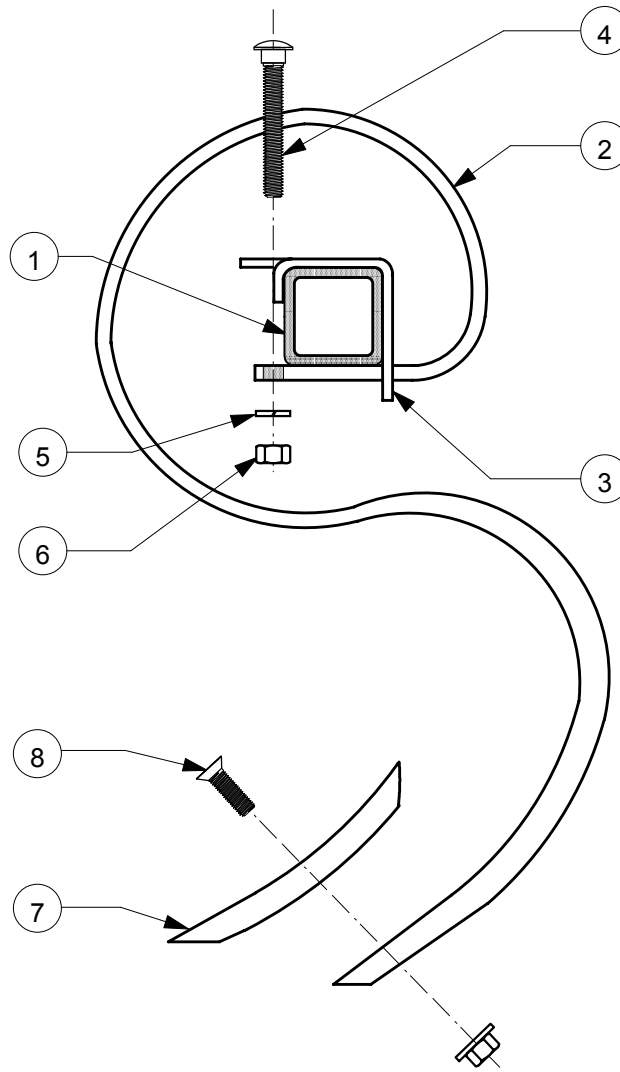

<u>Ref No.</u>	<u>New Part No.</u>	<u>Old Part No.</u>	<u>Description</u>	<u>Qty. *</u>
1.	SQT25W04		2-1/2" X 2-1/2" S-Tine Bar (specify length)	varies
2.	GST-50125S	SBM 2550A	1/2" X 1-1/4" S-Tine	varies
3.	GST-2CL250		2-1/2" S-Tine Bar Clamp	varies
4.	CBNC508064		1/2" X 4" Round Head Square Neck Bolt	varies
5.	LWASHER-08		1/2" Lock Washer	varies
6.	HXNUT-08NC		1/2" NC Hex Nut	varies
7.	GST-25150P	SBM 2551	1/4" Standard S-Tine Point	varies
8.	GST-0624BN	SBM 2552	3/8" X 1-1/2" Elliptical Head Metric Plow Bolt w/Nut	varies
9.	SBM 2553	SBM 2553	S-Tine Bar Clamp Assembly (includes items 3, 4, 5, and 6)	varies

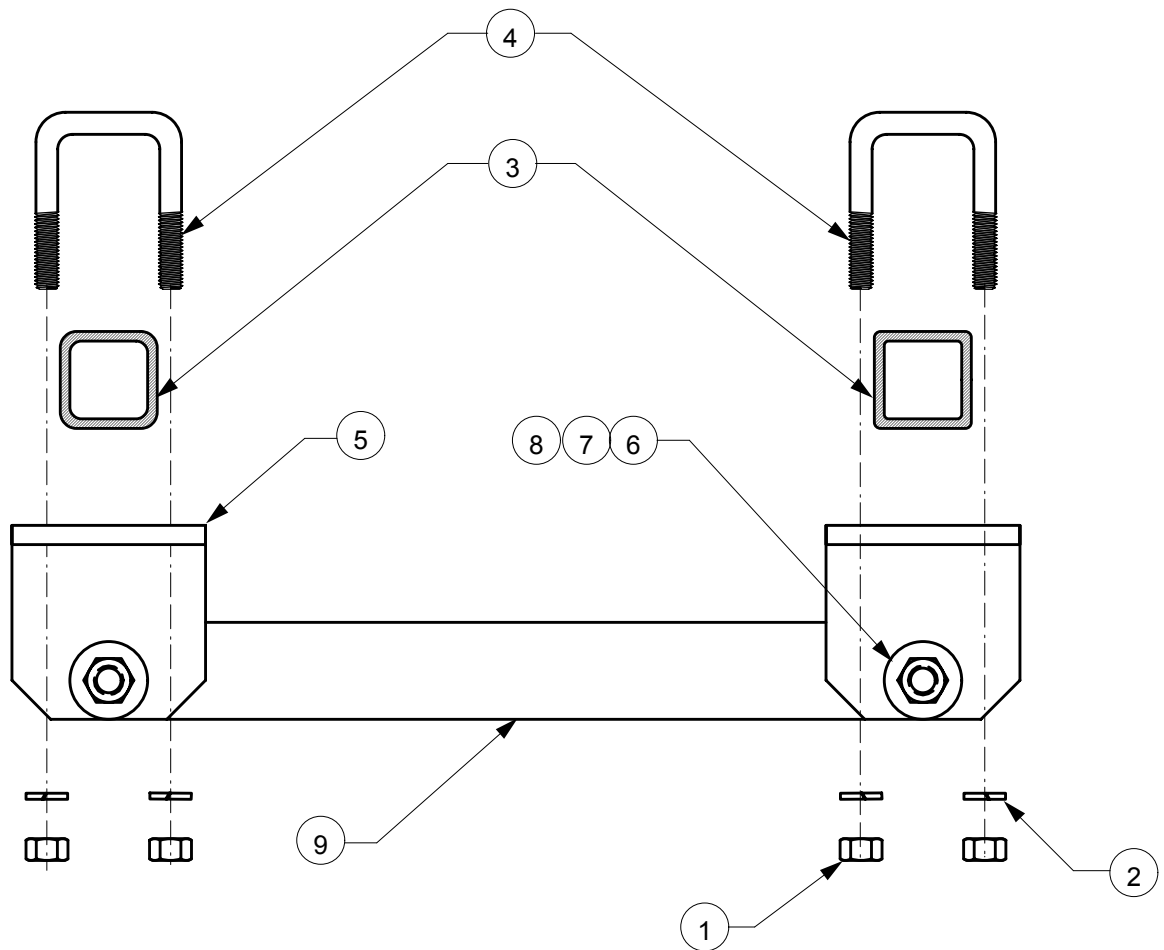

<u>Ref No.</u>	<u>Part No.</u>	<u>Description</u>	<u>Q-ty</u>
1.	HXNUT-10NC	5/8" NC Hex Nut	24
2.	LWASHER-10	5/8" Lock Washer	24
3.	SQT25W04	2-1/2" S-Tine Bar (specify length and location)	1
4.	UBNC10X41S	5/8" X 11" Sq. Bend U-bolt	12
5.	GPR-A50003	S-Tine Tie Clamp Bracket	12
6.	CSNC512040	3/4" X 2-1/2" NC Cap Screw Gr. 5	12
7.	FWASHER-12	3/4" Flat Washer	24
8.	NYNUT-12NC	3/4" NC Nylon Hex Nut	12
9.	FTB-00R402	S-Tine Tie Bar for 2-Bar Units	6



WHEEL AXLE BEARING ASSEMBLY

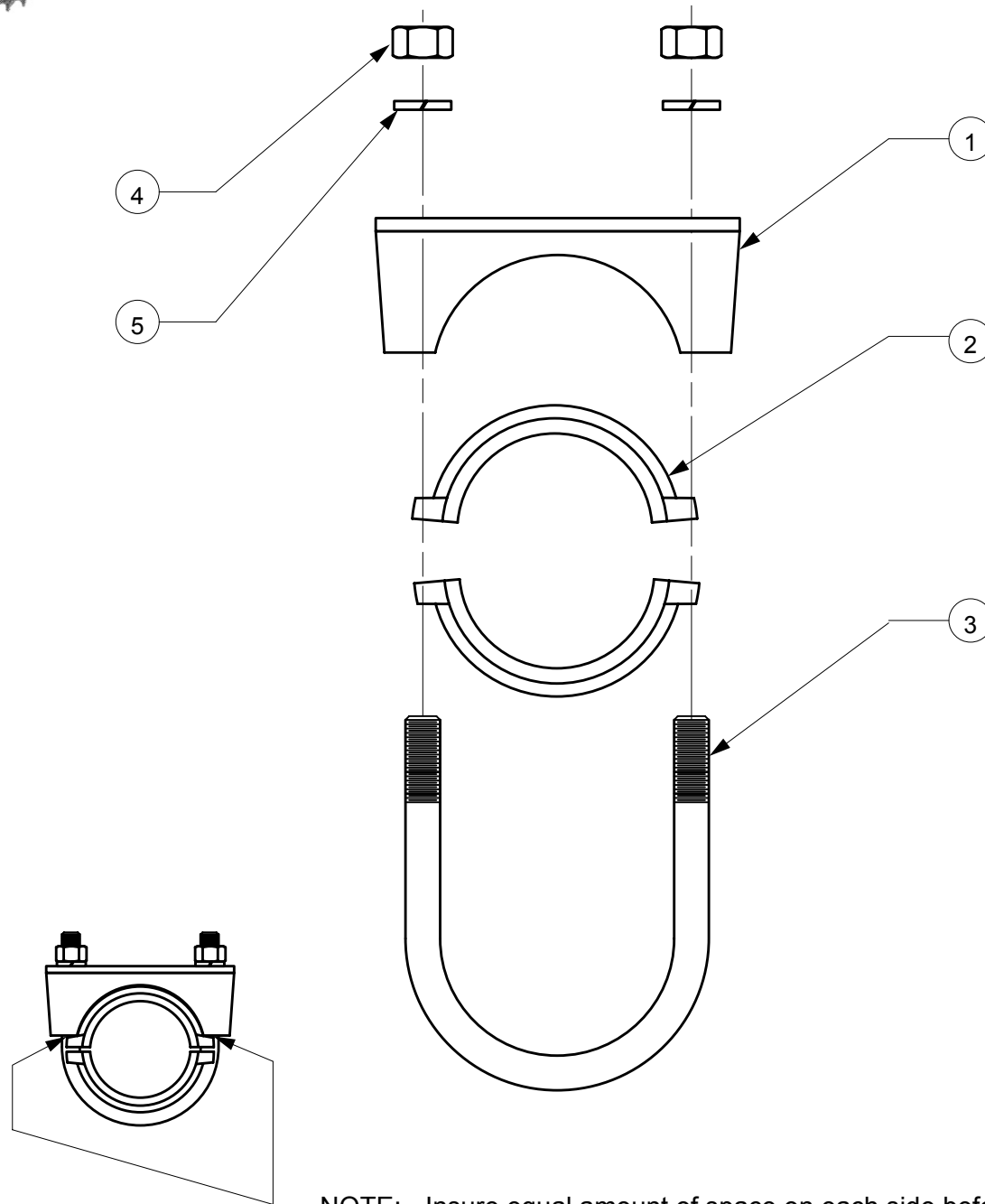

NOTE: - Insure equal amount of space on each side before tightening U-Bolts
 - Insure equal number of threads on each side of U-Bolt.

<u>Ref No.</u>	<u>Part No.</u>	<u>Description</u>	<u>Qty.</u>
1.	SLL 1351	Bearing Cradle Cap Weldment	4
2.	SLL 1350	Bearing Cap Casting Machined	8
3.	UBNC16122R	1" Bearing U-bolt	4
4.	HXNUT-16NC	1" NC Hex Nut	8
5.	LWASHER-16	1" Lock Washer	8
	SLL 1352	U-Bolt Assembly (includes items 3, 4, and 5)	
	SLL 1353	Axle Bearing Assembly (includes items 1, 2, 3, 4, and 5)	



T. G. SCHMEISER CO., INC. FOLDING TILL AN' BEDDER WHEEL AXLE ASSEMBLY

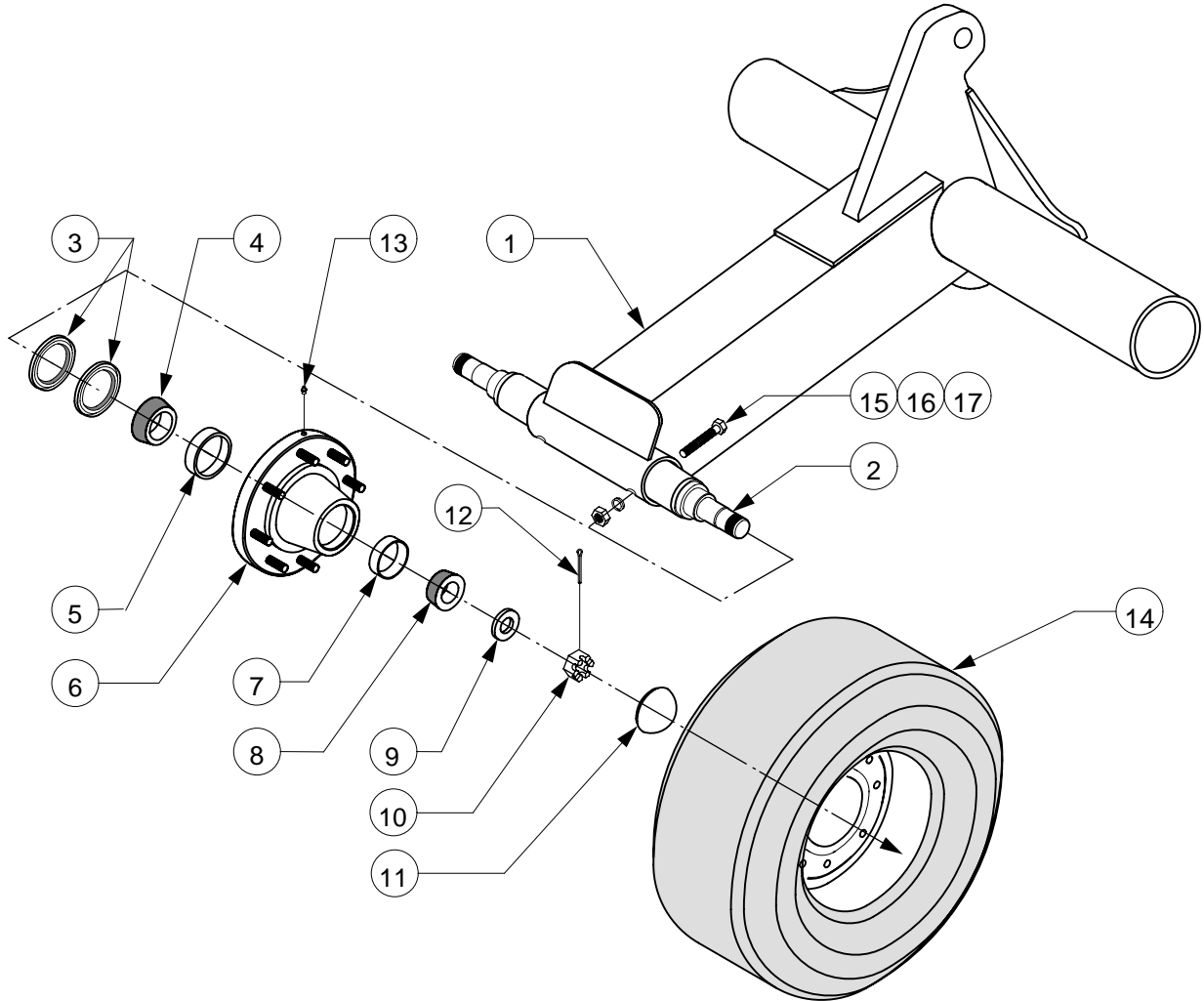

*** Note: For models with standard 6 on 6 hubs and removable spindles only.**

<u>Ref No.</u>	<u>Part No.</u>	<u>Description</u>	<u>Qty./ Machine</u>
1.	FTB-01M000	Tire Axle Weldment for 24' Units	1
	FTB-02M000	Tire Axle Weldment for 28' and 30' Units	1
2.	FTB-00M014	Wheel Axle Spindle 2-3/4" Removable	2
	FTB-00M008 *	Wheel Axle Spindle 2-1/8" Removable - for 6 on 6 Hubs	2 *
3.	GHB-8X8GSL	Grease Seal for 8 on 8 Heavy Duty Hub	8
4.	GHB-8X8ICN	Inner Bearing for 8 on 8 Heavy Duty Hub	4
5.	GHB-8X8IRC	Inner Race for 8 on 8 Heavy Duty Hub	4
6.	GHB-8X8XHZ	Heavy Duty 8 x 8 Hub Complete (includes items 3, 4, 5, 7, 8, and 13)	4
7.	GHB-8X8ORC	Outer Race for 8 on 8 Heavy Duty Hub	4
8.	GHB-8X8OCN	Outer Bearing for 8 on 8 Heavy Duty Hub	4
9.	FWASHER-14	7/8" Flat Washer	4
10.	GSP-14CANT	7/8" NF Castle Hex Nut	4
11.	GHB-8X8CAP	Dust Hub Cap for 8 on 8 Heavy Duty Hub	4
12.	GPN-03X32C	3/16" x 2" Cotter Pin	4
13.	GMB-ZERKTH	Threaded Zerk Fitting	4
14.	GWT-121614	12.5 x 16 14 Ply Tire with Wheel	4
15.	CSNC508072	1/2" x 4-1/2" Gr.5 NC Cap Screw	4
16.	LWASHER-08	1/2" Lock Washer	4
17.	HXNUT-08NC	1/2" NC Hex Nut	4



T. G. SCHMEISER CO., INC. ROCK SHAFT TO LEVELING PIPE FRAME ASSEMBLY

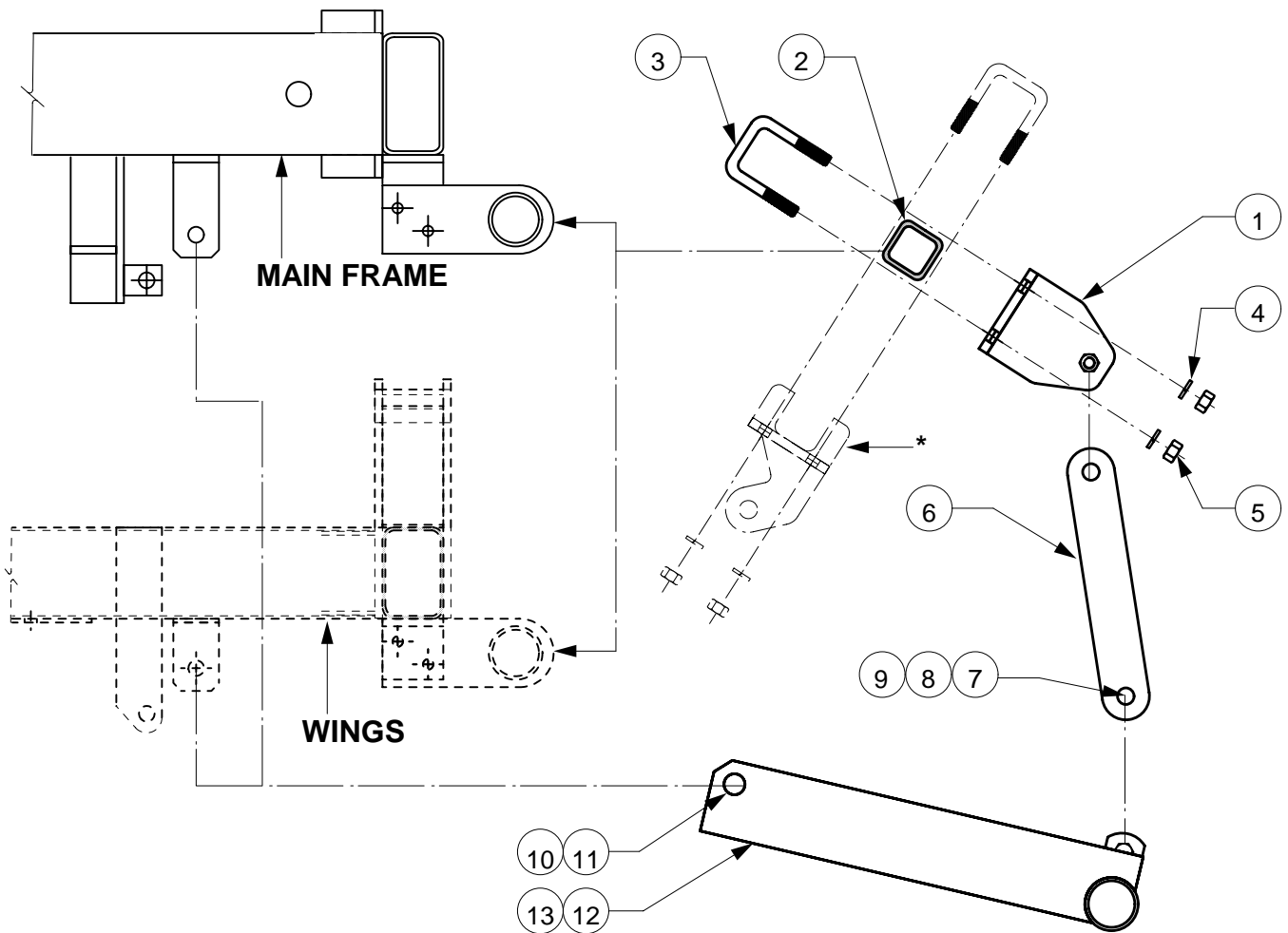

* Note orientation of Cylinder Anchor (*) in relation to Clevis Plates (1).

Ref No.	Part No.	Description	MF Qty.	Wings Qty.
1.	FTB-00Q300	Linkage Clevis Plates Weldment	4	4
2.	SQT25W04	2-1/2" Rock Shaft Tube (specify length)	1	2
3.	UBNC10X41S	5/8" X 11" Square Bend U-bolt	4	4
4.	LWASHER-10	5/8" Lock Washer	8	8
5.	HXNUT-10NC	5/8" Standard NC Hex Nut	8	8
6.	FTB-00Q500	Leveling Bar Link for 12" Tube, 14/20 Rings	4	4
	TBU-00L500	Leveling Bar Link for all other combinations	4	4
7.	CSNC512040	3/4" X 2-1/2" NC Cap Screw	4	4
8.	FWASHER-12	3/4" Flat Washer	4	4
9.	NYNUT-12NC	3/4" NC Nylon Hex Nut	4	4
10.	GPN-16X040	1" X 2-1/2" Clevis Pin	4	4
11.	GPN-040LYN	1/4" Lynch Pin	4	4
12.	FTB-01P000	24' Main Frame Leveling Pipe Weldment	1	
	FTB-02P000	28' and 30' Main Frame Leveling Pipe Wldmt	1	
13.	FTB-24P100	24' Wing Leveling Pipe Weldment - Pair		1
	FTB-28P100	28' Wing Leveling Pipe Weldment - Pair		1
	FTB-30P100	30' Wing Leveling Pipe Weldment - Pair		1

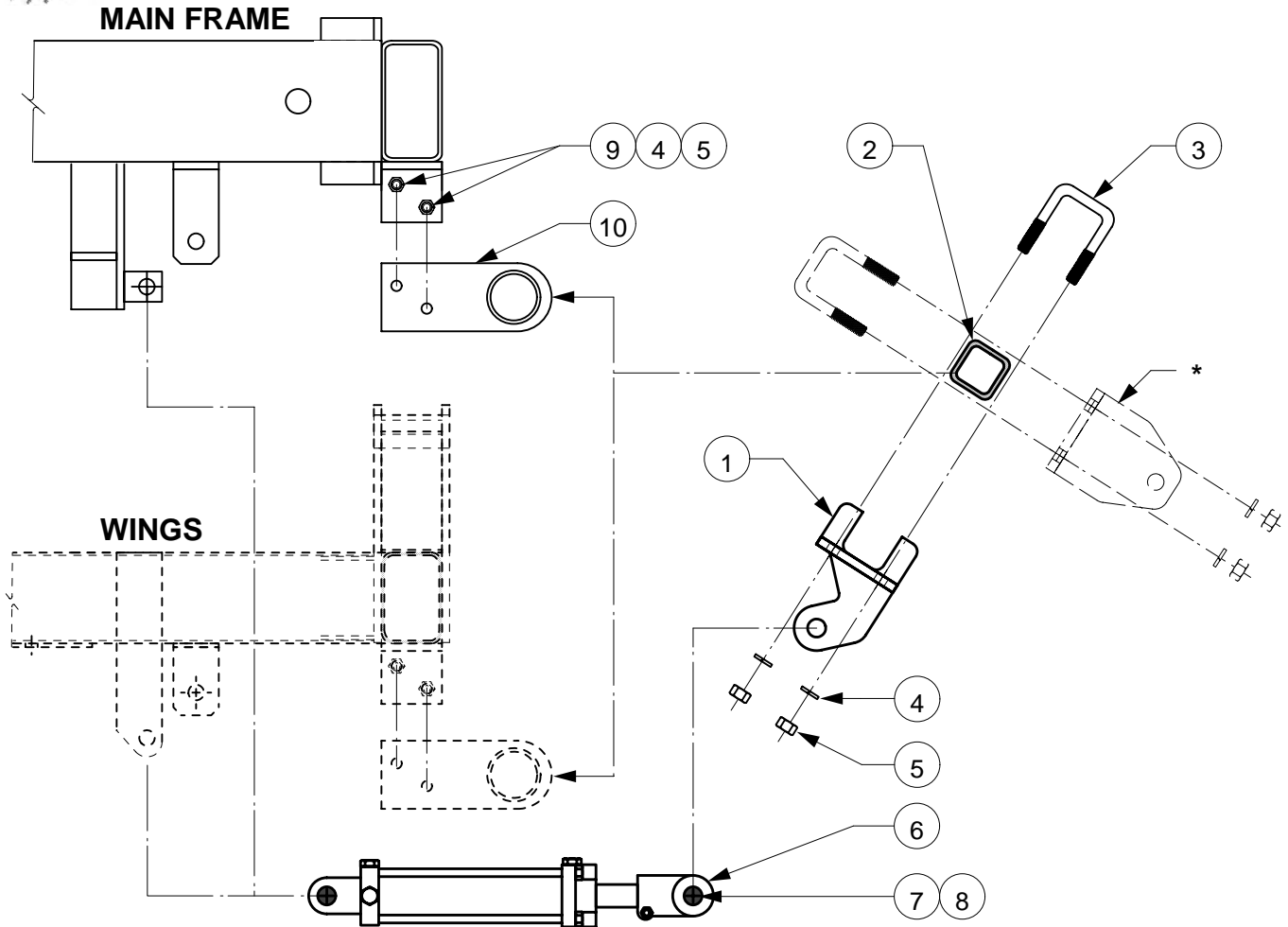

* Note orientation of Cylinder Anchor (1) in relation to Clevis Plates (*).

<u>Ref No.</u>	<u>Part No.</u>	<u>Description</u>	<u>MF Qty.</u>	<u>Wings Qty.</u>
1.	TBU-00L400	Lift Axle Hydraulic Cyl. Anchor Weldment	1	2
2.	SQT25W04	2-1/2" Rock Shaft Tube (specify length)	1	2
3.	UBNC10X41S	5/8" X 11" Square Bend U-bolt	10	20
4.	LWASHER-10	5/8" Lock Washer	24	44
5.	HXNUT-10NC	5/8" Standard NC Hex Nut	24	44
6.	GHC-25080T	2-1/2" X 8" Tie Rod Cylinder	1	2
7.	GPN-16X048	1" X 3" Clevis Pin	2	4
8.	GPN-04X28C	1/4" Cotter Pin	2	4
9.	CSNC510032	5/8" X 2" NC Cap Screw	4	4
10.	TBU-00L200	TB Lift Axle Bracket Weldment	4	4

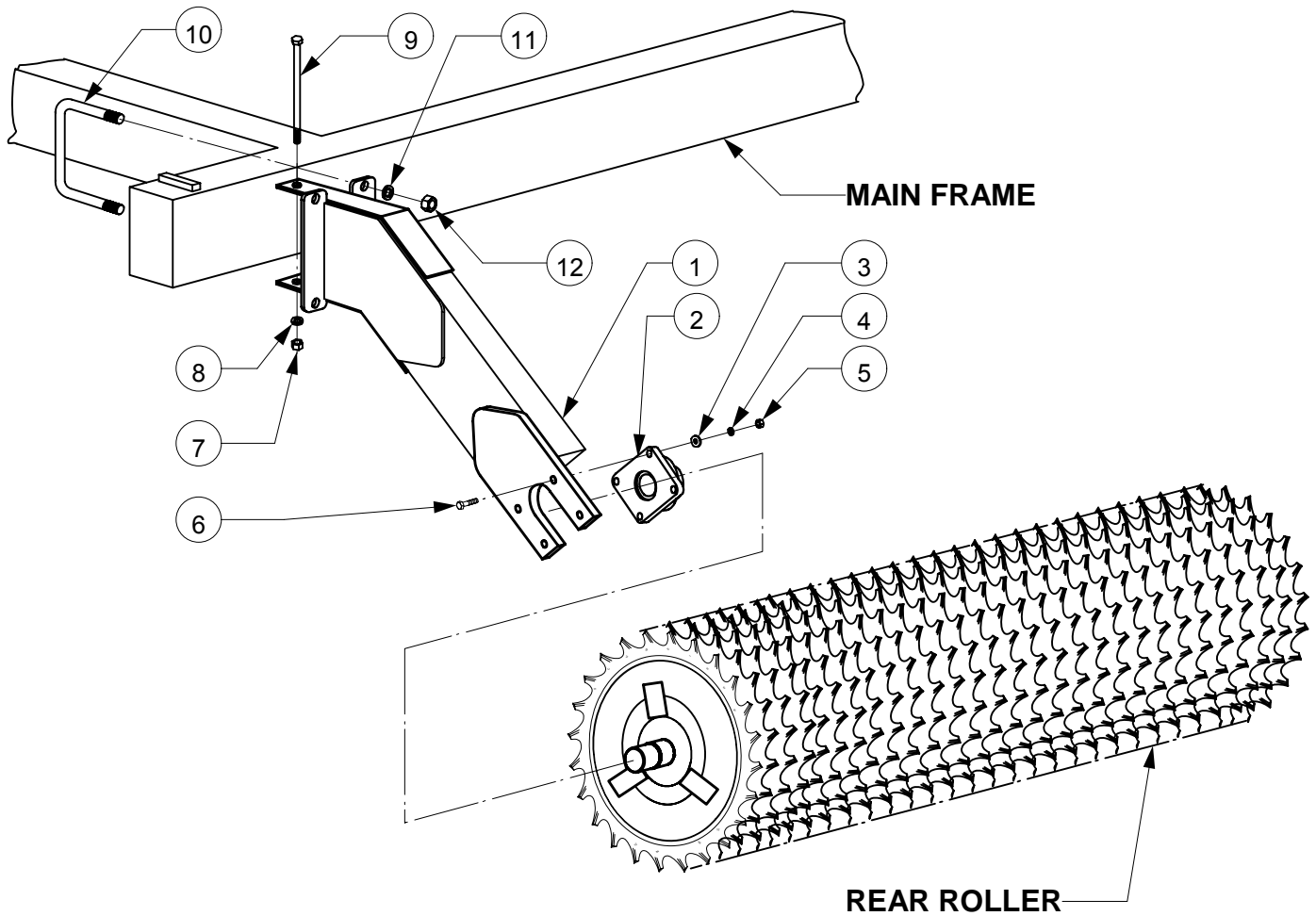

<u>Ref No.</u>	<u>Part No.</u>	<u>Description</u>	<u>Qty. per Roller Arm</u>
1.	FTB-00J000L(R)	Rear Roller Arm Weldment LH or RH	1
2.	TPP3157	1-15/16" Flange Bearing	2 / per roller
3.	FWASHER-08	1/2" Flat Washer	4 / per bearing
4.	LWASHER-08	1/2" Lock Washer	4 / per bearing
5.	HXNUT-08NC	1/2" NC Hex Nut	4 / per bearing
6.	CSNC508040	1/2" X 2-1/4" NC Cap Screw	4 / per bearing
7.	HXNUT-12NC	3/4" NC Hex Nut	1
8.	LWASHER-12	3/4" Lock Washer	1
9.	CSNC512160	3/4" X 10" NC Cap Screw	1
10.	UBNF14128S	7/8" NF Square U-Bolt	2
11.	LWASHER-14	7/8" Lock Washer	4
12.	HXNUT-14NF	7/8" NF Hex Nut	4

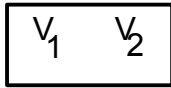

COUNTER BALANCE

- (1) V08CBBSUN - YAC BODY "SUN"
- (2) V08CBCARTR - CBEA LAN CARTS

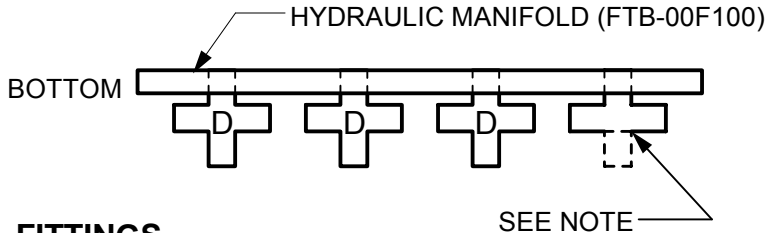
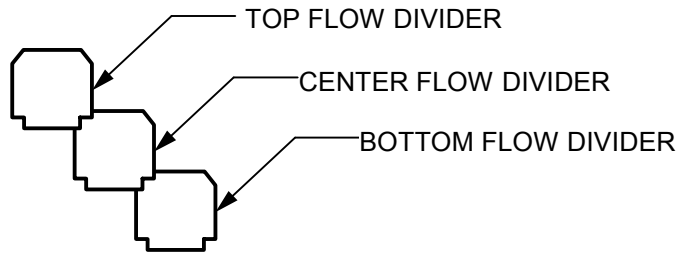

FITTINGS

- (D) FFPR080000 CROSS FITTING
- (E) FFPT080000 "T" FITTING

NOTE: (E) - FITTING FOR 24' & 28' UNITS
 (D) - FITTING FOR 30' UNITS

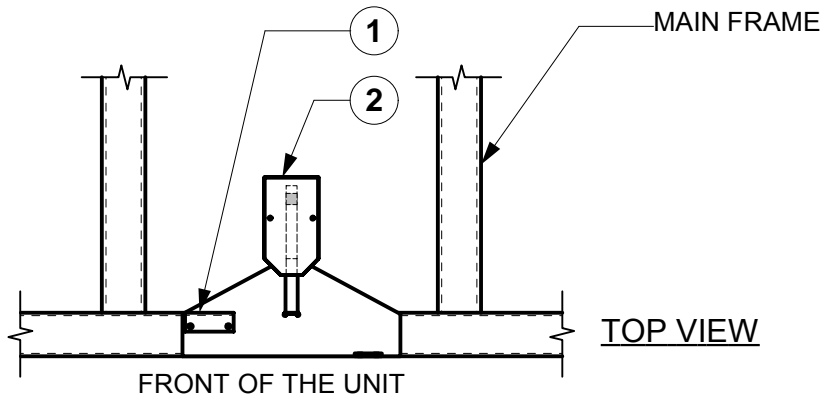

SET UP INSTRUCTIONS

1. MOUNT COUNTER BALANCE W/8MP-8FP 90' SWIVELS TO MOUNTING BRACKET (1)
2. MOUNT ALL FLOW DIVIDERS W/8MP-8FP 90' SWIVELS TO MOUNTING BRACKET (2)
3. INSTALL HYDRAULIC MANIFOLD WITH FITTINGS WELDED TO IT.
4. INSTALL ALL FITTINGS TO PROPER LOCATIONS
5. INSTALL ALL HOSES ACCORDING TO DIAGRAMS PROVIDED

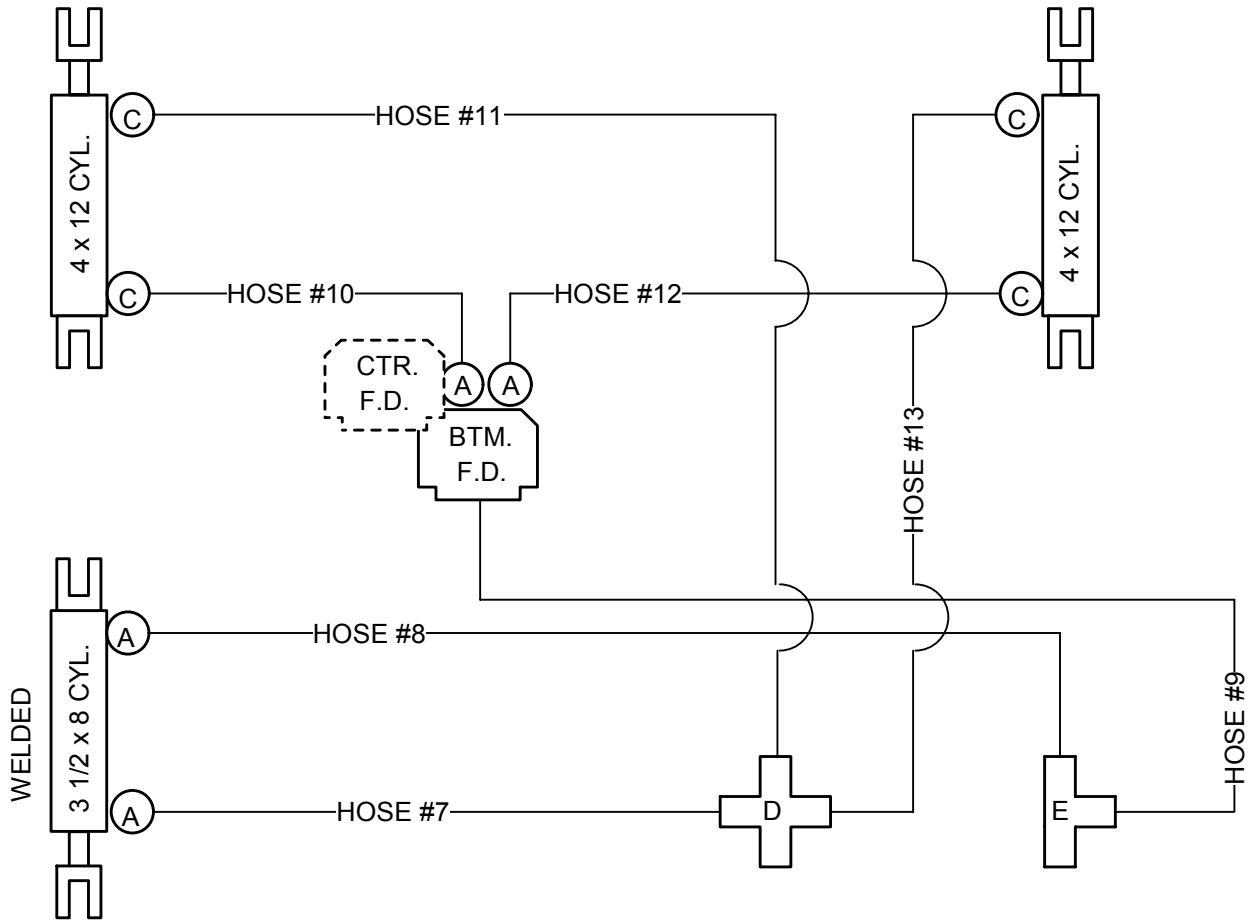

NOTE: FOR 24' & 28' UNITS ONLY

<u>HOSES</u>	<u>Unit Size</u>		<u>FITTINGS</u>	<u>Qty.</u>
	24'	28'		
HOSE #7	8MP-8MP	27"	(A) 8MP-8FP-90°	6
HOSE #8	8MP-8MP	27"	(C) 8MB-8FP-90°	4
HOSE #9	8MP-8MPX	33"	(D) FP-8 CROSS FITTING	1
HOSE #10	8MP-8MP	50"	(E) FPT-8 "T" FITTING	1
HOSE #11	8MP-8MP	75"		
HOSE #12	8MP-8MP	50"		
HOSE #13	8MP-8MP	67"		

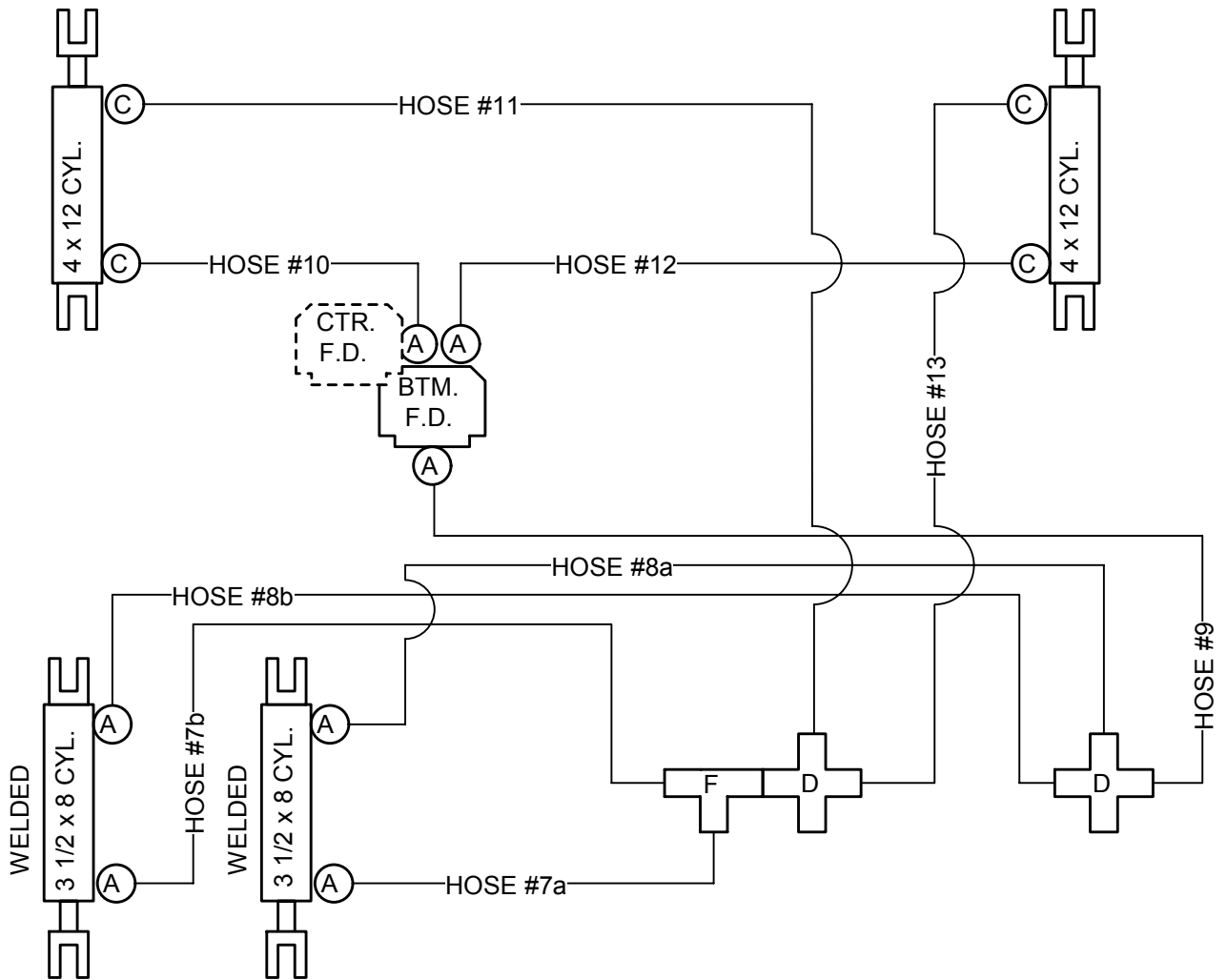

NOTE: FOR 30' UNITS ONLY

<u>HOSES</u>		<u>FITTINGS</u>		<u>Qty.</u>
HOSE #7a	19"	(A) 8MPx8FP 90° SWIVLE		7
HOSE #7b	29"	(C) 8MBx8FP 90° SWIVLE		4
HOSE #8a	28"	(D) FP-8 CROSS FITTING		2
HOSE #8b	36"	(F) MP-FP-FP-8 "T" FITTING		1
HOSE #9	48"			
HOSE #10	65"			
HOSE #11	98"			
HOSE #12	65"			
HOSE #13	74"			

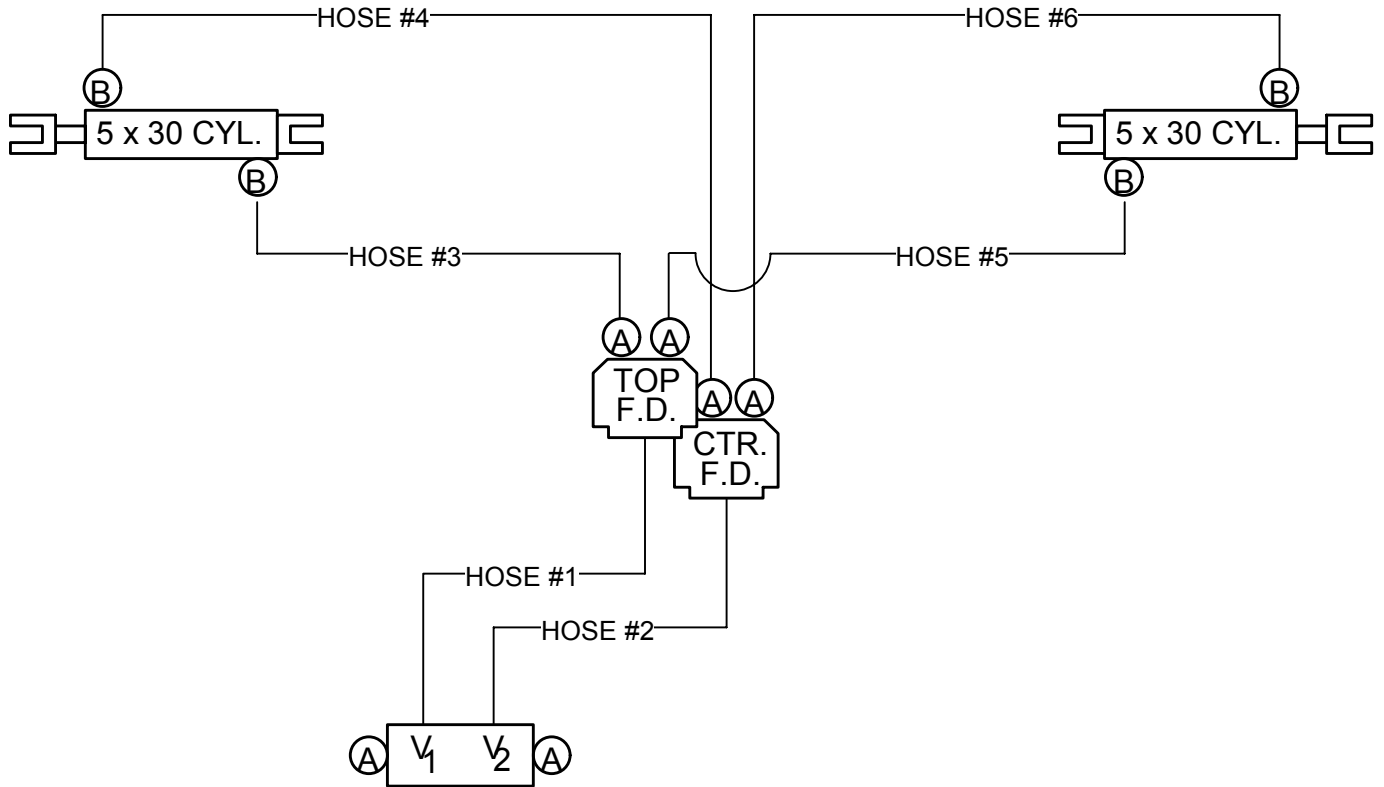

NOTE: ALL HOSES ARE
8MP x 8MP.

F.D. = FLOW DIVIDER

HOSES:		UNIT SIZE			FITTINGS	
		24'	28'	30'		Qty.
HOSE #1	8MP-8MPX	23"	23"	29"	(A) 8MP-8FPX-90°	6
HOSE #2	8MP-8MPX	21"	21"	29"	(B) 10MP-8FPX-90°	4
HOSE #3	8MP-8MP	23"	35"	31"		
HOSE #4	8MP-8MP	52"	64"	67"		
HOSE #5	8MP-8MP	23"	35"	35"		
HOSE #6	8MP-8MP	52"	64"	70"		

COUNTER BALANCE	
(1)	YAC BODY "SUN"
(2)	CBEA LAN CARTRIDGE

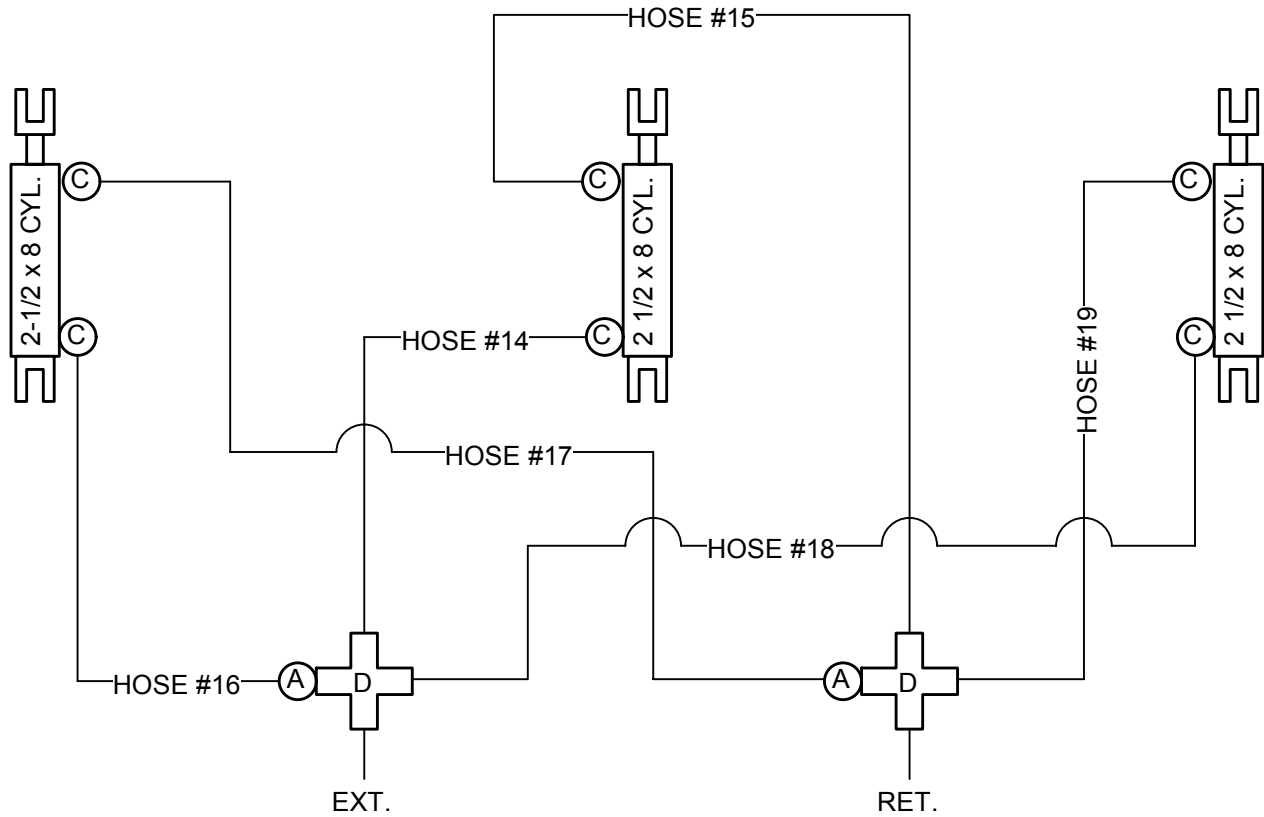

	HOSES			Unit Size			FITTINGS		Qty.
		24'	28'	30'					
#14	8MP-8MP	102"	102"	96"	(A) 8MP-8FP-90°	6			
#15	8MP-8MP	113"	113"	109"	(C) 8MB-8FP-90°	6			
#16	8MP-8MP	148"	154"	182"	(D) FPX-8 CROSS FITTINGS	2			
#17	8MP-8MP	154"	166"	188"					
#18	8MP-8MP	138"	138"	157"					
#19	8MP-8MP	144"	148"	165"					

T.G. SCHMEISER CO., INC.®

Limited Warranty Statement

T. G. Schmeiser Co., Inc. warrants each new Schmeiser® product to be free from defects in material and workmanship. This warranty is applicable only for the normal service life expectancy of the product or components, not to exceed twelve (12) consecutive months from the date of delivery of the new Schmeiser product to the original purchaser.

Genuine T. G. Schmeiser Co., Inc. replacement parts and components will be warranted for 90 days from date of purchase, or the remainder of the original equipment warranty period, whichever is longer.

Under no circumstances will it cover any merchandise or components thereof, which, in the opinion of the company, has been subjected to misuse, unauthorized modifications, alteration, an accident or if repairs have been made with parts other than those obtainable through T. G. Schmeiser Co., Inc.

The Company in no way warrants engines, batteries, cylinders, tires or other trade accessories since these items are warranted separately by their respective manufacturer. Expendable components such as points, shanks, blades, rings, bearings, teeth, and the like are excluded from this warranty.

Our obligation under this warranty shall be limited to repairing or replacing, free of charge to the original purchaser, any part that, in our judgment, shall show evidence of such defect, provided further that such part shall be returned within thirty (30) days from date of failure to T. G. Schmeiser Co., Inc., routed through the dealer and distributor from whom the purchase was made, transportation charges prepaid.

This warranty shall not be interpreted to render T. G. Schmeiser Co., Inc. liable for injury or damages of any kind or nature to person or property. This warranty does not extend to the loss of crops, loss because of delay in harvesting, or any expense or loss incurred for labor, substitute machinery, rental or for any other reason.

Except as set forth above, T. G. Schmeiser Co., Inc. shall have no obligation or liability of any kind on account of any of its equipment and shall not be liable for special or consequential damages. T. G. Schmeiser Co., Inc. makes no other warranty, expressed or implied, and, specifically, T. G. Schmeiser Co., Inc. disclaims any implied warranty or merchantability or fitness for a particular purpose. Some states or provinces do not permit limitations or exclusions of implied warranties or incidental or consequential damages, so the limitations or exclusion in this warranty may not apply.

This warranty is subject to any existing conditions of supply, which may directly affect our ability to obtain materials or manufacture replacement parts.

T. G. Schmeiser Co., Inc. reserves the right to make improvements in design or changes in specifications at any time, without incurring any obligation to owners of units previously sold.

No one is authorized to alter, modify or enlarge this warranty nor the exclusion, limitations and reservations.

**WARRANTY VOID IF NOT REGISTERED
WITHIN 30 DAYS OF PURCHASE DATE**